



PRESSURE CONNECTIONS CORP.

610 Claycraft Road, Columbus OH 43230 • Phone (614) 863-6930 – Fax (614) 864-1327

Certified ISO 9001:2008 Registered Firm • www.PressureConnections.com

Quote #708-18a

New Lower Prices!!!
SAME DAY SHIPPING
 on all orders
 received by 4:30 P.M.
 4:30 PM EST

Aeroquip 5100 Interchange Wing Nut 'WET-LINE' Coupler

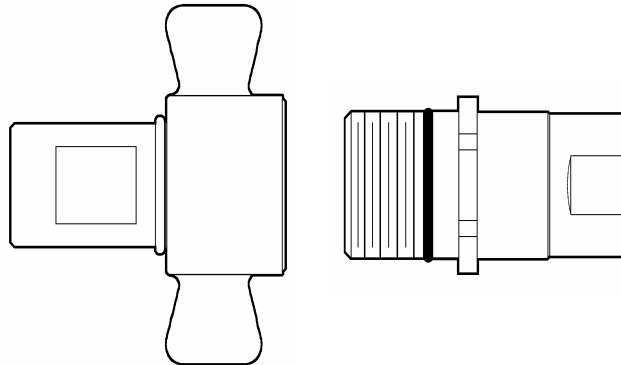

	Body	Pipe	Part No.	Net	Working PSI	Aeroquip	Parker	Snap-tite	Dust Cover	Net	STEEL Dust Caps & Plugs
S O C K E T	3/4	1/2	51WC-12-08	\$21.24	3,000	-	6135-08	-	51C-12P	\$7.33	
	3/4	3/4	51WC-12	20.48	3,000	5100-S5-12B	6120-12	B78C12-12F	51C-12P	7.33	
	1"	1"	51WC-16	22.87	3,000	5100-S5-16B	6120-16	B78C16-16F	51C-16P	7.84	
	1 1/4	1 1/4	51WC-20	37.32	2,750	5100-S5-20B	6120-20	B78C20-20F	51C-20P	11.23	
	1 1/2	1 1/2	51WC-24	74.65	2,500	5100-S5-24B	6120-24	B78C24-24F	51C-24P	19.17	
N I P P L E	3/4	1/2	51N-12-08	14.55	3,000	-	6105-08	-	51N-12C	6.80	
	3/4	3/4	51N-12	13.86	3,000	5100-S2-12B	6105-12	B78N12-12F	51N-12C	6.80	
	1"	1"	51N-16	16.72	3,000	5100-S2-16B	6105-16	B78N16-16F	51N-16C	7.37	
	1 1/4	1 1/4	51N-20	32.98	2,750	5100-S2-20B	6105-20	B78N20-20F	51N-20C	11.07	
	1 1/2	1 1/2	51N-24	71.80	2,500	5100-S2-24B	6105-24	B78N24-24F	51N-24C	18.40	
F L A N G E	3/4	-	51F-12	1.71	-	150-22-12	6107-12	78F-12	-	-	Mounting Flange
	1"	-	51F-16	2.33	-	150-22-16	6107-16	78F-16	-	-	
	1 1/4	-	51F-20	2.94	-	150-22-20	6107-20	78F-20	-	-	
	1 1/2	-	51F-24	3.73	-	150-22-24S	6107-24	78F-24	-	-	
3:1 Safety Factor											

Features & Options:

The 5100 Series Interchange is a Thread-To-Connect coupling that features a Connect-Under-Pressure design. It also features No-Spill Valving that makes it environmentally friendly. This Hi-Flow Tubular Steel Valving creates less turbulence, which results in a Low Pressure Drop. These qualities make the 5100 Series Interchange suitable for a wide range of applications including; Construction, Forestry, Oil & Gas Industries, Marine/Defense, Transportation, Utility, etc.

This coupling is NOT rated for continuous hydraulic IMPULSE applications.

Dust Caps and Plugs play a vital role in QD longevity as they help to keep out contaminants that can harm the efficiency of your hydraulic system.

- Thread-To-Connect Heavy Duty Wing Nut Design makes Connection and Disconnection Easy.
- Hex Nut Couplers are in the Master Listing Pages.
- Brass Body with Steel Nut, Stainless Steel is Available.
- Connect-Under-Pressure Design.
- Flanged Bonded Valve Prolongs Coupling Life and Provides Minimal Fluid Loss and Air Inclusion.
- Hi-Flow Tubular Valve Increases Flow by Reducing the Turbulence That Causes Pressure Drop.
- Dust Seal Keeps Out Contaminates and Offers Visual "Connected OK" Feature.
- Bulkhead Mount Design w/ Flange.
- Standard Buna-N Seal, Optional Seals are Available.
- Female Pipe (NPTF) Standard, Other Threads are Available.



Your Quality Connection